

PROJECT NAME AND ADDRESS -

PROPOSED RESIDENTIAL BUILDING PLAN
FOR PLOT NO. 2020

GENERAL NOTES -

1. ALL DIMENSIONS ARE IN FEET & INCHES.
2. ALL DIMENSIONS ARE TO BE READ NOT TO SCALE OTHERWISE MENTIONED.
3. BRICK USED IN MASONRY SHALL HAVE CRUSHING STRENGTH NOT LESS THAN 100KG/CM2.
4. THE REINFORCEMENT SHALL BE OF HIGH STRENGTH DEFORMED BARS AS PER I.S.1786-1985 ,FE 500N/MM².
5. THIS DRAWING SHOULD BE READ IN CONJUNCTION WITH OTHER RELEVANT ARCHITECTURAL, STRUCTURAL, MECHANICAL AND ELECTRICAL DRAWINGS AND ALL RELEVANT SECTIONS OF THE SPECIFICATIONS.
6. CHECK THE LEVEL OF THE SITE WITH THE MAIN ROAD LEVEL AS REFERENCE BEFORE FINALIZING THE P.L.
7. MINIMUM NOMINAL COVER TO ALL REINFORCEMENT I/C. LINKS IF ANY SHALL BE AS PER IS 456-2000 AS UNDER:- (1) FOUN. =50 mm. (2) COLUMN = 40 mm (3) BEAMS = 25 mm (4) SLABS = 20 mm
8. MIN. GAP BETWEEN TWO BARS =25 MM.
9. LAP LENGTH / ANCHORAGE LENGTH i) 50 d IN CASE OF FOUND., BEAM & SLAB ii) 45 d IN CASE OF COLUMN WHERE d IS DIA
10. CONC. MIX RATIO FOR P.C.C. IS 1:5:10
11. HOOKES FOR TIES/STIRRUPS =10 X DIA OF BAR.
12. IN THE EVENT OF ANY SITE CONDITIONS REFER BACK TO THE OFFICE .
13. THE FOUNDATION HAS BEEN DESIGNED FOR ASSUMED SAFE BEARING CAPACITY OF 11 TON/M2.
14. ALL STRUCTURAL ELEMENTS ARE DESIGNED FOR M-25 CONCRETE FE-500 STEEL.
15. THIS FOUNDATION IS DESIGNED FOR G.F. + F.F.
16. ALL 9" THK. WALLS CONSIDERED AS LOAD BEARING

ARCHITECTS :

COPY RIGHT -

This drawing is the property of Base Design and cannot be copied or reproduced in any form without prior permission.

No.	Revision/Issue	Date



Structure Designer and Project Management Consultants

B-305, Agarsen Society, Sector-76, Mohali
Mob : +91 ,998-8968898, +91 ,998-8768898,

DEALT BY- ER. SHUBHAM DHAMEJA	SHEET - US/FP/08
CHECKED BY - ER. AMANDEEP SINGH	DATE - 13-02-2024
DRG. TITLE - BEAM DETAILS	SCALE - NOT TO SCALE

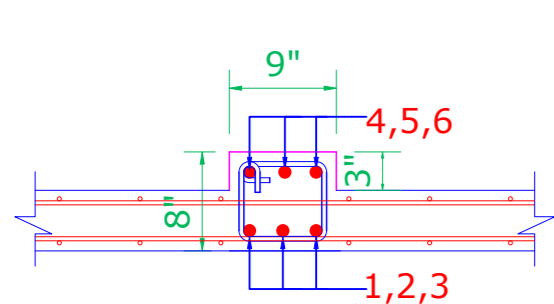

DETAIL OF CB-201

REINFORCEMENT DETAIL

1,3,4,6 - 16 Ø (THR'-OUT)
2,5 - 12 Ø (THR'-OUT)
STRP'S - 8 Ø @ 5" C/C

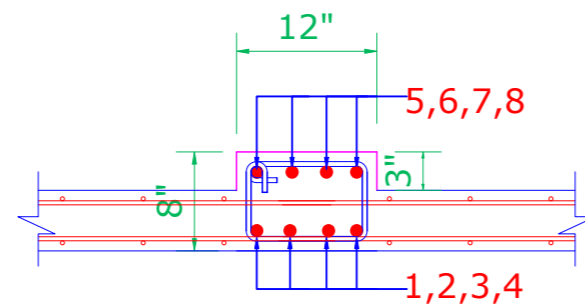

DETAIL OF CB-202

REINFORCEMENT DETAIL

1,4,5,8 - 16 Ø (THR'-OUT)
2,3,6,7 - 16 Ø (THR'-OUT)
STRP'S - 8 Ø @ 5" C/C

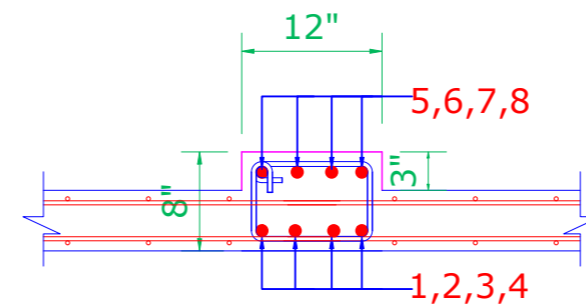

DETAIL OF CB-202A

REINFORCEMENT DETAIL

1,4,5,8 - 20 Ø (THR'-OUT)
2,3,6,7 - 16 Ø (THR'-OUT)
STRP'S - 8 Ø @ 5" C/C

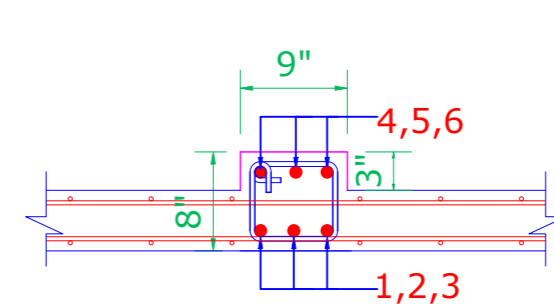

DETAIL OF CB-203

REINFORCEMENT DETAIL

1,3,4,6 - 16 Ø (THR'-OUT)
2,5 - 12 Ø (THR'-OUT)
STRP'S - 8 Ø @ 4" C/C

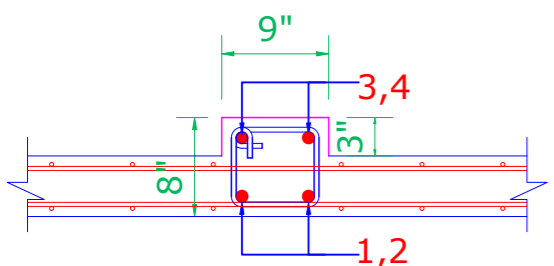

DETAIL OF CB-204

REINFORCEMENT DETAIL

1,2 - 12 Ø (THR'-OUT)
3,4 - 12 Ø (THR'-OUT)
STRP'S - 8 Ø @ 5" C/C

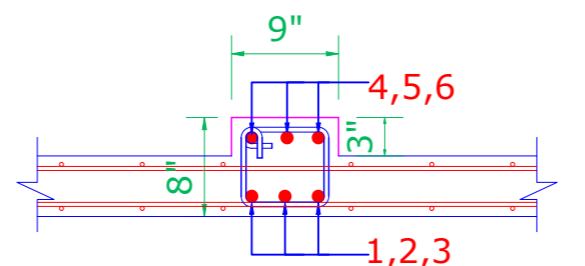

DETAIL OF CB-205

REINFORCEMENT DETAIL

1,3,4,6 - 16 Ø (THR'-OUT)
2,5 - 20 Ø (THR'-OUT)
STRP'S - 8 Ø @ 5" C/C

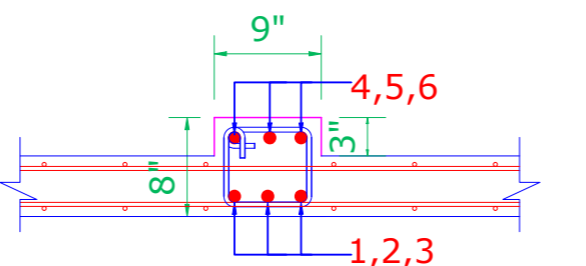

DETAIL OF CB-206

REINFORCEMENT DETAIL

1,3,4,6 - 16 Ø (THR'-OUT)
2,5 - 16 Ø (THR'-OUT)
STRP'S - 8 Ø @ 5" C/C

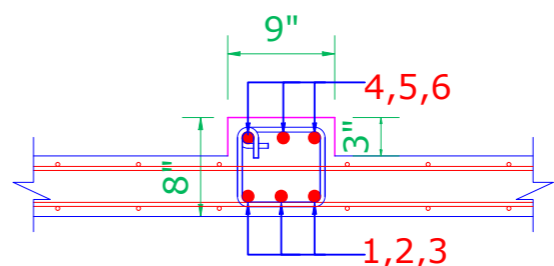

DETAIL OF CB-207

REINFORCEMENT DETAIL

1,3,4,6 - 12 Ø (THR'-OUT)
2,5 - 12 Ø (THR'-OUT)
STRP'S - 8 Ø @ 5" C/C

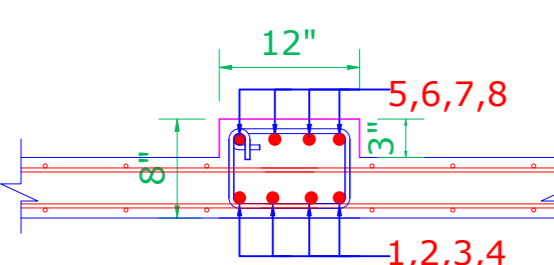

DETAIL OF CB-208

REINFORCEMENT DETAIL

1,4,5,8 - 16 Ø (THR'-OUT)
2,3,6,7 - 16 Ø (THR'-OUT)
STRP'S - 8 Ø @ 5" C/C

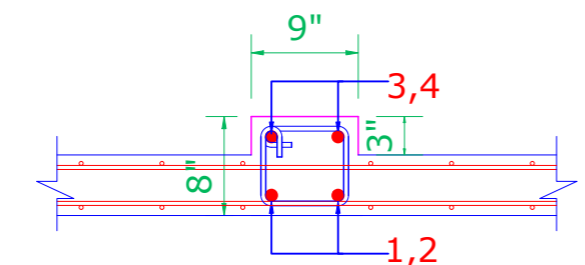

DETAIL OF CB-209

REINFORCEMENT DETAIL

1 TO 4 - 16 Ø (THR'-OUT)
STRP'S - 8 Ø @ 5" C/C

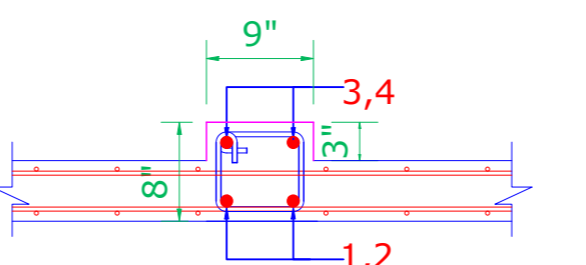

DETAIL OF CB-210

REINFORCEMENT DETAIL

1,2 - 16 Ø (THR'-OUT)
3,4 - 16 Ø (THR'-OUT)
STRP'S - 8 Ø @ 4" C/C

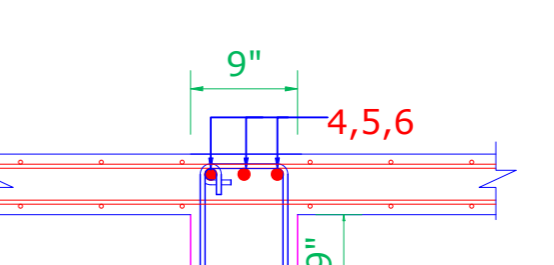

DETAIL OF B-201

REINFORCEMENT DETAIL

1 TO 4,6 - 16 Ø (THR'-OUT)
5 - 16 Ø (E.O.S.)
STRP'S - 8 Ø @ 5" C/C